

# TECMount™

# 284

## USER'S MANUAL



**HIGH POWER MOUNT**

# Table of Contents

Introduction .....	3
Installation and Use.....	3
Mounting Plates.....	5
Connector Pin-Outs.....	5
SENSOR Switch .....	6
Technical Specifications .....	6
Configuring the Temperature Controller.....	7
Using the Thermistor on Standard Versions .....	7
Using the RTD on 150°C Versions .....	8
Operating at High Temperatures .....	11
Mechanical Drawings.....	12
Warranty .....	15
Service and Support .....	15

## Introduction

Thank you for choosing the **284 TECMount** from Arroyo Instruments. The **284 TECMount** is designed for high performance and long term use.

The **284 TECMount** integrates a high power Peltier cooler for precise control and substantial heating and cooling capacity for your powerful devices. The standard **284 TECMount** has an operating range of +15°C to +85°C, and the **-150** version allows operation up to 150°C, covering a broad range of temperature control needs.

The **284 TECMount** comes standard with an integrated fan for additional cooling capacity. When used with the **5300 Series TECSource** temperature controllers, no additional power supply is needed to power the fan, or use a standard external 12V DC power supply when connecting to other temperature controllers.

The **284 TECMount** also offers all the features you would expect from a modern diode fixture, including:

- Hard nickel over 100% oxygen free copper thermal plate.
- Designed to be quickly integrated with Arroyo's **TECSource** instruments.
- Industry-standard D-sub connector and pin-outs allow for quick integration into existing laser applications.

## Installation and Use

If you are using an Arroyo Instruments **5300 Series TECSource** temperature controller, the fan supply is built directly into the **TECSource**. You will need to enable the fan supply in the **TECSource** menu – see the **TECSource** manual for additional details on how to do that.

If you are using a third-party temperature controller, then you will need to provide a 12V DC power supply either through the DB-15 connection or the 2.1mm DC power jack. See the pin-out below for the fan pin assignments.

## NOTE

### Earth Grounding Considerations

The DB-15 connector shell is electrically connected to the housing. Depending on the wiring of your cables and instruments, this may or may not provide earth grounding of the fixture. Make sure the cable shell is earth grounded on both ends of the cable, and that the instrument makes connection from its connector to earth ground.

### Connect to the TEC Controller:

Next, connect the **284 TECMount** to your temperature controller. Make sure the temperature controller's current limit is set to a maximum value of 7.4A. Where possible, we recommend the use of Arroyo Instruments TEC cables. Use p/n 1262 TECSource Cable for the temperature controller connection.

## NOTE

Arroyo Instruments offers TEC cables designed to connect directly between our **TECSource** products. If you use your own cables, ensure the connections are properly made between the instrument and the mount, and that proper grounding techniques are used. The pin-out of the connectors can be found later in this document.

## Mounting Plates

The **284 TECMount** is available in a standard bread board configuration with M2.5 holes on 10mm centers. Custom versions of the cold plate are available, contact the factory for details. Your **284** may be configured with a custom mounting plate, and if so, this manual should be accompanied by drawing for your plate.

## Connector Pin-Outs

DB-15 Pin	Description
1, 2, & 9	TE (+)
3, 4, & 10	TE (-)
7	Thermistor / Sensor+
8	Thermistor / Sensor-
11	FAN (+)
12	FAN (-)
13	No Connection
14	RTD Sense (+) (-150 only)
15	RTD Sense (-) (-150 only)

**DB-15 Connector Pin-Out**

Phoenix Pin	Description
1	TE (+)
2	TE (-)
3	Thermistor
4	Thermistor
5	Sensor+ (Input)
6	Sensor- (Input)

**Phoenix 6-Pin Connector Pin-Out**

### Sensor Polarity and 4-Wire Connections

While the thermistor and RTD inputs are not polarized, when using a 4-wire RTD connection to the **284-xx-150** mount, it is important to properly connect the polarity of the sense wires to the sensor. Pins 7 and 14 should be one polarity (+) and pins 8 and 15 should be the opposite polarity (-). If polarities are not matched, the instrument will indicate a sensor error.

## SENSOR Switch

The **284** features a SENSOR switch to quickly switch between internal and external temperature sensors. With the SENSOR switch in the INT position, the internal thermistor embedded in the cold plate is used to provide the feedback for the temperature controller (pins 7 & 8 [and 14 & 15 on **284-xx-150** models] on the DB-15 connector, and S+ and S- on the Phoenix connector). With the SENSOR switch in the EXT position, the EXT+ and EXT- inputs on the Phoenix connector are connected to pins 7 & 8 [and 14 & 15 on **284-xx-150** models] on the DB-15 connector, and S+ and S- on the Phoenix connector.

## Technical Specifications

### 284 **TECMount**

#### COLD PLATE

##### Mounting Holes

284-01 Cold Plate

M3

284-03 Cold Plate

M2.5

#### TEMPERATURE CONTROL

##### Standard Version

Temperature Range (°C)

+15 to +85

Sensor Type

BetaTHERM 10K3A1IA

10kΩ Thermistor

##### High Temperature Version

Temperature Range (°C)

+15 to +150

Sensor Type

100Ω Platinum RTD

0.00385 Ω / Ω / °C

##### TE Module (at 25°C)<sup>1</sup>

I<sub>max</sub> = 7.4A

V<sub>max</sub> = 16.4V

#### INPUT CONNECTORS

##### Temperature Controller

DB-15, male

Phoenix 6-Pin, male

##### External Fan Power

2.1mm round jack, center positive

12VDC, 210mA max

#### GENERAL

Size (H x W x D) [in(mm)]

4.75 (120.7) x 4.4 (111.8) x 4.4 (111.8)

Fixture Mounting holes

Side holes for ¼-20 screws (post mount)

8-32 holes top and bottom

<sup>1</sup> See *Operating at High Temperatures*, below, for additional requirements at high temperatures

## Configuring the Temperature Controller

When using an Arroyo Instruments temperature controller, the easiest method for configuring the controller to operate with the mount is to change the **Mount** setting in the menu. Select either **284** or **284-150**, depending if you have the standard or 150°C version of the **284**, respectively. This will change the sensor settings, current limit, and fan settings to be appropriate for this mount.

If you will be using a non-Arroyo controller, make sure to adjust the limits and sensor settings appropriately to ensure proper and safe operation of the mount.

## Using the Thermistor on Standard Versions

The standard version of the **284 LaserMount** is equipped with a 10k $\Omega$  negative temperature coefficient (NTC) thermistor, specifically, the BetaTHERM 10K3A1. A thermistor works by translating temperature into resistance, with resistance decreasing as temperature increases (hence the 'negative coefficient').

Below is the response curve of the thermistor:

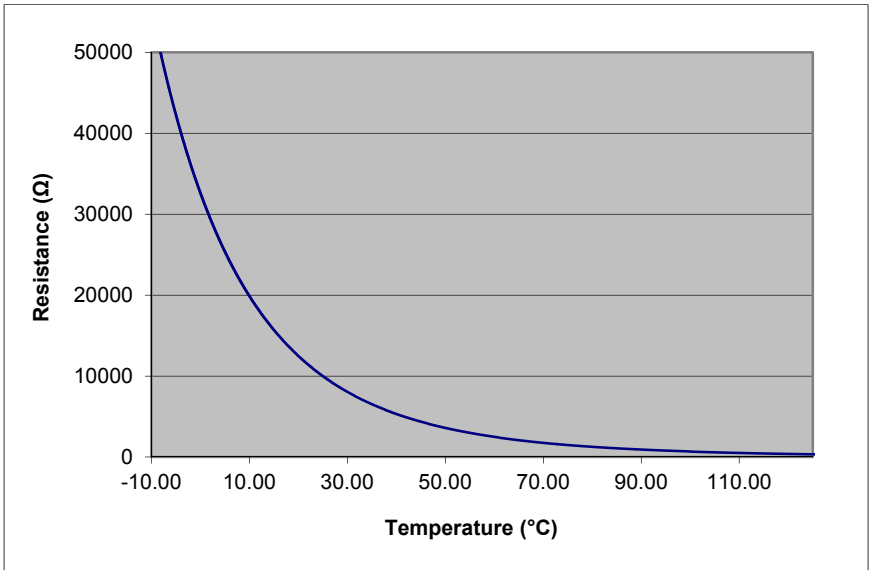

**Resistance vs. Temperature Graph**

As can be seen by the graph, the resistance of the thermistor drops very quickly. In the typical control range (0 $^{\circ}\text{C}$  to 40 $^{\circ}\text{C}$ ), typical 10K thermistors offer good

sensitivity to changes in temperature, and this is the range in which most 10K thermistors are typically used. 10K thermistors can be used at much higher temperatures, but will suffer poorer temperature stability performance because of the lower sensitivity.

All Arroyo temperature controllers support operation using a 10µA or 100µA thermistor bias, which limits the upper control range to 450kΩ or 45kΩ, respectively. To minimize noise and maximize stability, you should select highest current while still allowing you full operation across your required temperature range. The typical setting is 100µA, but your application will determine the actual needs.

### The Steinhart-Hart Equation

As can be seen from the temperature versus resistance graph above, resistance varies inversely with temperature in a non-linear fashion. This relationship can be accurately modeled by polynomial equations, and one such being the Steinhart-Hart equation:

$$\frac{1}{T} = A + B * \ln(R) + C * \ln(R)^3$$

The coefficients for the BetaTHERM 10K3A1 thermistor are:

$$A = 1.12924 \times 10^{-3}$$

$$B = 2.34108 \times 10^{-4}$$

$$C = 0.87755 \times 10^{-7}$$

These are the default coefficients for Arroyo Instruments temperature controllers, but can be changed in the **Sensor** menu, or by selecting the appropriate **284** mount from the **Mount** menu setting.

## Using the RTD on 150°C Versions

The **284 LaserMount** can optionally be configured for up to 150°C operation. To support this high temperature operation, a RTD sensor with a 0.00385 Ω / Ω / °C sensitivity is used. Like thermistors, RTDs also function by converting temperature into resistance, but unlike thermistors, RTDs increase in resistance as temperature increases. RTDs are also a fairly linear device, meaning they can be used across a much broader temperature control range.

You can identify a 150°C configured **284** by its part number: a “-150” will be added to the end, for example, **284-03-150**.



According to IEC751, the resistance/temperature relationship is determined using one of two equations, dependent on the temperature or resistance value being measured. For resistances above the  $R_0$  value (resistance at 0°C, typically 100Ω, as is the case with the RTD used in the **284**) of the RTD, the following equation is used:

$$R = R_0(1 + AT + BT^2)$$

Below  $R_0$ , an additional term is added to the equation:

$$R = R_0[1 + AT + BT^2 + C(T - 100)T^3]$$

In both of these equations,  $R_0$  is the resistance of the RTD at 0°C, and A, B, and C are the coefficients as defined by IEC751, through regression analysis, or by using the Callendar-van Dusen method.

Not all Arroyo Instruments temperature controllers support RTD operation. Check with the factory for the recommended controller, as high temperature operation typically requires a higher voltage than is normally available with the standard **5305** and **5310** controllers (see *Operating at High Temperatures*, below).

For the Arroyo Instruments controllers that support RTD sensors, the default coefficients are not correct for this mount. They must be changed to use the 0.00385 Ω / Ω / °C curve, which has the following coefficients:

$$\begin{aligned} A &= 3.9080 \times 10^{-3} \\ B &= -0.58019 \times 10^{-6} \\ C &= -4.2735 \times 10^{-12} \\ R_0 &= 100 \end{aligned}$$

These coefficients can be changed in the Sensor menu, or by selecting the appropriate **284** mount from the **Mount** menu setting.

## 2-Wire versus 4-Wire Measurements

One concern in using RTDs are their relatively low resistance (typically 100Ω at 0°C), and small Ω/°C. Because of these two factors, the resistance of the cable used to connect to the sensor can become a significant error in the sensor measurement. Most Arroyo Instruments controllers offer two RTD measurement modes: a conventional two wire measurement mode, which is subject to this error, and a four wire measurement mode that uses separate sensor and source lines to remotely sense the actual resistance of the RTD and eliminate the cable or connector resistances.

When using 4-wire measurement mode, you must select 'RTD (4-wire)' as the sensor type, and then connect the Sensor+ and Remote Sensor+ at one side of the RTD, and Sensor- and Remote Sensor- to the other side of the RTD. Make these connections as close to the sensor as possible.

The drawings below illustrate how 2-wire and 4-wire connections work. Note that 4-wire measurements require all four wires to be brought through the cable to the mount. The **1262 TECSource** cable carries this connection through to the mount, but the **1260B** cable does not.

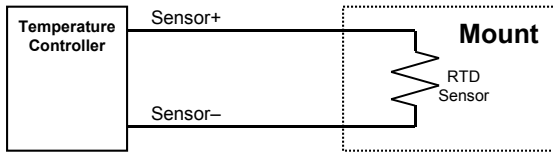

**RTD 2-wire Measurement**

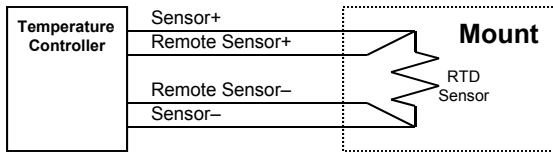

**RTD 4-wire Measurement**

## Operating at High Temperatures

The **284-xx-150** (150°C-capable version) has additional requirements that should be considered when operating in the upper temperature range:

1. The voltage requirements of the TEC increase significantly when operating at the higher temperatures, so much so that the standard **5305** or **6300 Series** controllers will be voltage limited when controlling the mount. To gain the maximum performance of the **285-xx-150**, the recommended controller is a **5300-08-24**, which has an 8A / 24V output and will provide the best possible performance with the mount. Contact the factory for more details.
2. Turn off the mount fan when operating significantly above ambient. By turning off the fan, you reduce the cooling efficiency on the heat sink, which is desirable when operating at high temperature, and will reduce the amount of TEC power required to reach and maintain the target temperature. However, you may still need the fan if you will be operating the mount under heavy thermal load such that it is cooling even at elevated temperatures. Note that the body of the heat sink will become warm, and could reach temperatures of up to 50°C.

# Mechanical Drawings

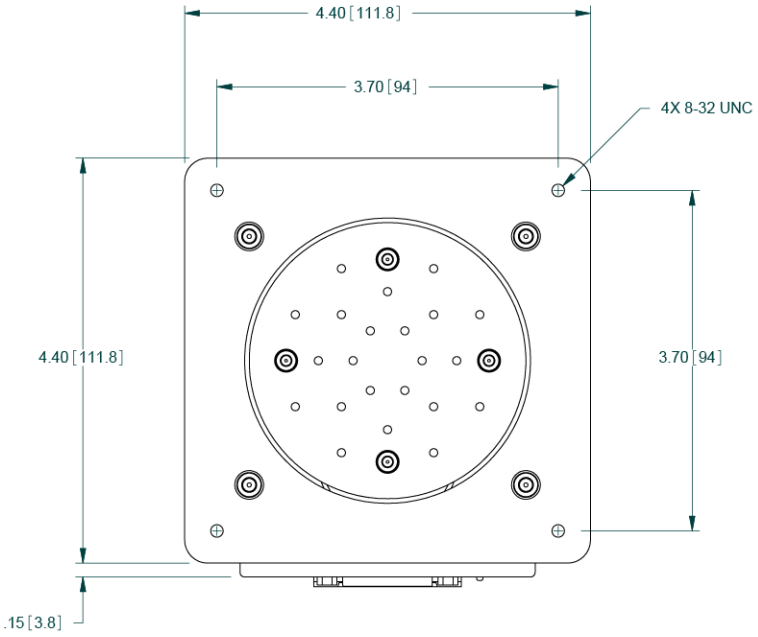

Top View

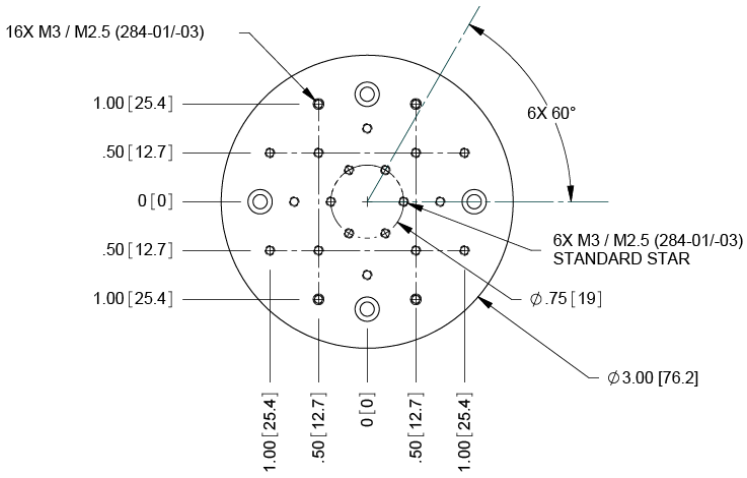

Plate Detail A

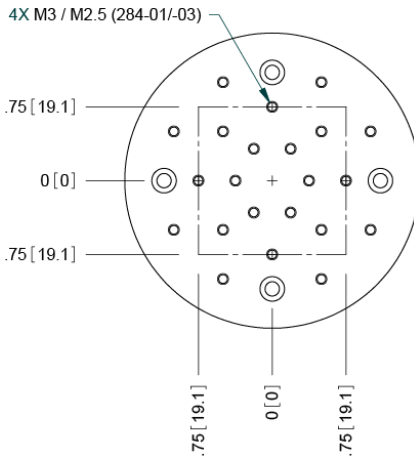
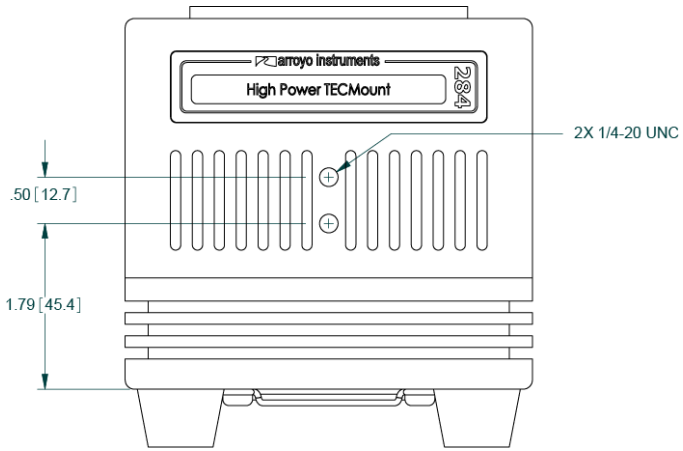
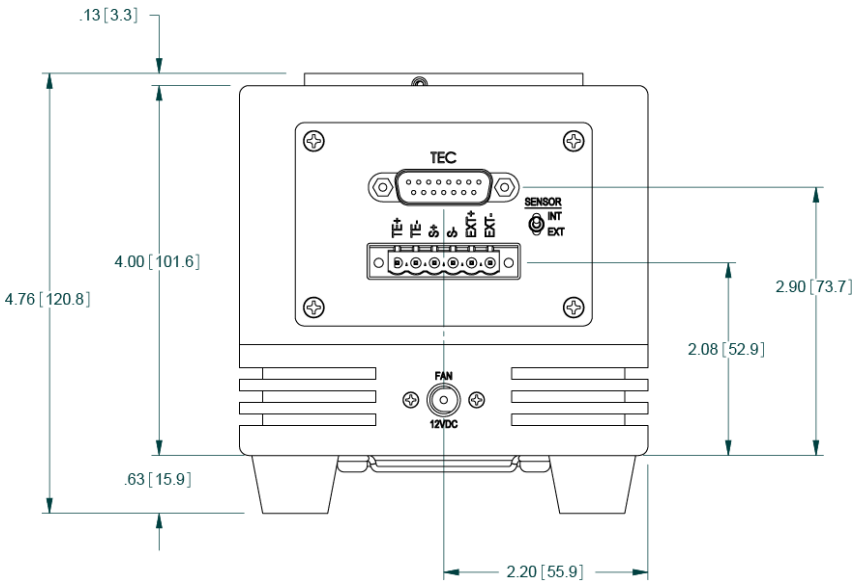

Plate Detail B



Front View



Rear View

## Warranty

Arroyo Instruments warrants this product to be free from defects in material and workmanship under normal use and service for a period of one (1) year from date of shipment. It does not apply when the product has been misused, altered or damaged by accident or abnormal conditions of operation. If found to be defective during the warranty period, the product will either be repaired or replaced at Arroyo Instruments's option.

THIS WARRANTY IS IN LIEU OF ALL OTHER WARRANTIES, EXPRESSED OR IMPLIED, INCLUDING IMPLIED WARRANTIES OF MERCHANTABILITY OR FITNESS FOR ANY PARTICULAR PURPOSE. ARROYO INSTRUMENTS SHALL NOT BE LIABLE FOR ANY INDIRECT, SPECIAL, OR CONSEQUENTIAL DAMAGES RESULTING FROM THE PURCHASE OR USE OF ITS PRODUCTS.

## Service and Support

For service and support, contact your local distributor or Arroyo Instruments.

Telephone: +1 (805) 543-1302  
Facsimile: +1 (805) 543-1303  
Email: [support@arroyoinstruments.com](mailto:support@arroyoinstruments.com)  
Web: <http://www.arroyoinstruments.com>  
Address: 1201 Prospect Street  
San Luis Obispo, CA 93401  
USA



1201 Prospect Street, San Luis Obispo, CA 93401

Tel: (805) 543-1302 Fax: (805) 543-1303

**[sales@arroyoinstruments.com](mailto:sales@arroyoinstruments.com)**

**[www.arroyoinstruments.com](http://www.arroyoinstruments.com)**